



4C33

POWER TRIODE

FORCED-AIR COOLED

Intended especially for pulsed operation

4C33

GENERAL DATA

Electrical:

Heater, for Unipotential Cathode:

Voltage 5.0 ac or dc volts

Current 9.1 amp

Starting Current: The heater current must never exceed 16 amperes, even momentarily.

Minimum Cathode

Heating Time 2 minutes

Amplification Factor 25

Direct Interelectrode Capacitances (Approx.):^o

Grid to Plate 13 μf

Grid to Cathode 34 μf

Plate to Cathode 0.7 μf

^o with no external shield.

Mechanical:

Terminal Connections:

H - Heater

G - Grid Terminal
(Flange)

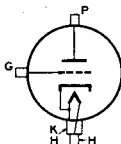

K - Cathode

P - Plate Terminal
(Radiator)

Mounting Position Vertical, with radiator up or down

Overall Length 4-25/32" \pm 3/32"

Greatest Diameter 2.056" \pm 0.006"

Radiator Integral Part of Tube

Air Flow:

Through Radiator (for max. rated dissipation) 18 min. cfm

The specified air flow at a static pressure of 0.48 inch of water should be delivered through the radiator toward the bulb before and during application of any voltages.

Radiator Temperature (Measured on the core at end away from incoming air) 180 max. $^{\circ}\text{C}$

Grid-Flange Temperature 140 max. $^{\circ}\text{C}$

Glass Temperature 165 max. $^{\circ}\text{C}$

PLATE - PULSED OSCILLATOR—Class C

Maximum Ratings, Absolute Values:

For operating frequencies up to 625 Mc

PEAK PLATE PULSE SUPPLY VOLTAGE 13000 max. volts

PEAK GRID-BIAS VOLTAGE -2000 max. volts

PEAK PLATE CURRENT FROM PULSE SUPPLY 30 max. amp

PEAK RECTIFIED GRID CURRENT 4 max. amp

DC PLATE CURRENT 0.030 max. amp

DC GRID CURRENT 0.004 max. amp

PEAK PLATE INPUT 390000 max. watts

PLATE DISSIPATION 250 max. watts

PULSE LENGTH 5 max. μsec

4C33



4C33

POWER TRIODE

Typical Operation as Self-Excited

Plate-Pulsed Oscillator at 600 Mc

Rectangular Pulse Shape

Peak Plate Pulse Supply Voltage.	9000	volts
Peak Plate Current from Pulse Supply	27	amp
Peak Rectified Grid Current.	3	amp
Peak Power Output.	130000	watts
Duty Factor.	0.001	
Cathode Resistor *	10	ohms
Pulse Repetition Frequency	200	cps

Maximum Circuit Values:

Grid-Circuit Resistance.	200 max.	ohms
----------------------------------	----------	------

* It is recommended that the entire bias be obtained from a cathode resistor. In certain applications, partial grid-resistor bias may be used provided the grid-circuit resistance does not exceed the indicated maximum value.

CHARACTERISTICS RANGE VALUES FOR EQUIPMENT DESIGN

	<u>Note</u>	<u>Min.</u>	<u>Max.</u>	
Heater Current	1	8.2	10.0	amp
Grid-Plate Capacitance	-	11.5	15.5	$\mu\mu\text{f}$
Grid-Cathode Capacitance	-	27	41	$\mu\mu\text{f}$
Plate-Cathode Capacitance.	-	0.5	0.9	$\mu\mu\text{f}$
Power Output During Pulse.	1,2	125000	-	watts

Note 1: With 5 volts on heater.

Note 2: With "dc plate voltage during pulse" of 9000 volts, cathode resistor of 10 ohms, pulse length of 5 microseconds, duty factor of 0.001, and frequency of 600 Mc.



4C33

POWER TRIODE

*obsolete
9/60*

4C33

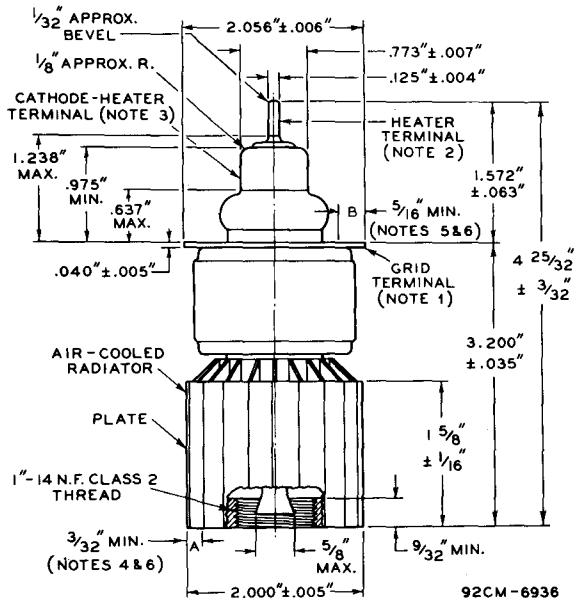

NOTE 1: MAXIMUM ECCENTRICITY OF ϕ (AXIS) OF GRID-TERMINAL FLANGE WITH RESPECT TO ϕ (AXIS) OF PLATE RADIATOR IS 0.040", MEASURED WITHIN $1/32$ " OF BOTTOM OF RADIATOR.

NOTE 2: MAXIMUM ECCENTRICITY OF ϕ (AXIS) OF HEATER TERMINAL WITH RESPECT TO ϕ (AXIS) OF CATHODE-HEATER TERMINAL IS 0.020".

NOTE 3: MAXIMUM ECCENTRICITY OF ϕ (AXIS) OF CATHODE-HEATER TERMINAL WITH RESPECT TO ϕ (AXIS) OF GRID-TERMINAL FLANGE IS 0.020".

NOTE 4: SURFACE OF ANNULAR AREA INDICATED BY "A" ON BOTTOM OF RADIATOR IS IN SAME PLANE WITHIN 0.005", AS DETERMINED BY GAUGE $1/16$ " WIDE AND 0.005" THICK. THIS GAUGE WILL NOT ENTER MORE THAN $1/16$ " WITH BOTTOM OF RADIATOR RESTING ON FLAT PLATE.

NOTE 5: SURFACE OF ANNULAR AREA INDICATED BY "B" ON GRID-TERMINAL FLANGE IS IN SAME PLANE WITHIN 0.008", AS DETERMINED BY GAUGE METHOD DESCRIBED IN NOTE 4.

NOTE 6: SURFACE OF ANNULAR AREA INDICATED BY "A" ON BOTTOM OF RADIATOR IS PARALLEL WITHIN 0.030" TO SURFACE OF ANNULAR AREA INDICATED BY "B" ON GRID-TERMINAL FLANGE.