

Power Triode

FORCED-AIR COOLED

GENERAL DATA

Electrical:

Filament, Multistrand Thoriated Tungsten:

Excitation.	Single-Phase AC or DC
Voltage ^a	11 ± 5% volts
Current at heater volts = 11.	285 amp
Minimum heating time.	15 sec
Amplification Factor for grid volts = -50, plate amperes = 2.	40

Direct Interelectrode Capacitances

(Approx.):

Grid to plate	50	μμf
Grid to filament.	90	μμf
Plate to filament	1.5	μμf

Mechanical:

Operating Position.	Vertical, filament end up
Maximum Overall Length.	25"
Maximum Diameter.	17"
Weight (Approx.).	228 pounds
Radiator.	Integral part of tube
Air Jacket.	RCA-241F1

F - Filament

G - Grid

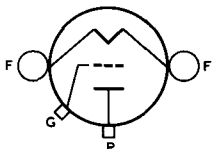

P - Plate

Thermal:

Air Flow:

Through radiator—The specified air flow for various plate dissipations as indicated below should be delivered by a blower vertically upward through the radiator before and during the application of any voltages. Filament power, plate power, and air may be removed simultaneously.

Plate Dissipation.	15	20	25	kw
Air Flow	1100	1450	1800	cfm
Static Pressure.	0.85	1.5	2.2	in. of water

To filament seals. 10 min. cfm

The specified air flow should be directed from a 1-1/4"-diameter nozzle into the filament header before and during the application of any voltages to limit the temperature of the filament seals to the maximum value.

← Indicates a change.



Input Air Temperature (To radiator)	45 max.	°C
Radiator Temperature.	180 max.	°C
Bulb Temperature.	180 max.	°C
Seal Temperature (Filament, grid, and plate).	165 max.	°C

AF POWER AMPLIFIER and MODULATOR — Class B

Maximum CCS^b Ratings, Absolute-Maximum Values:

DC PLATE VOLTAGE.	15000 max.	volts
MAX.-SIGNAL DC PLATE CURRENT ^c	6 max.	amp
MAX.-SIGNAL PLATE INPUT ^c	90 max.	kw
PLATE DISSIPATION ^c	25 max.	kw

Typical Operation:

Values are for 2 tubes

Filament Voltage.	10	11	volts
DC Plate Voltage.	10200	15000	volts
DC Grid Voltage	-220	-320	volts
Peak AF Grid-to-Grid Voltage.	900	1600	volts
Zero-Signal DC Plate Current.	0.6	0.6	amp
Max.-Signal DC Plate Current.	5.8	10	amp
Effective Load Resistance (Plate to plate).	3600	3320	ohms
Max.-Signal Driving Power (Approx.) ^d	120	600	watts
Max.-Signal Power Output (Approx.)	37	100	kw

PLATE-MODULATED RF POWER AMPLIFIER — Class C Telephony

*Carrier conditions per tube for use
with a max. modulation factor of 1*

Maximum CCS^b Ratings, Absolute-Maximum Values:

DC PLATE VOLTAGE.	12500 max.	volts
DC GRID VOLTAGE	-2000 max.	volts
DC PLATE CURRENT.	4.5 max.	amp
DC GRID CURRENT	1 max.	amp
PLATE INPUT	55 max.	kw
PLATE DISSIPATION	17 max.	kw

Typical Operation:

At 1.6 Mc

Filament Voltage.	10	11	volts
DC Plate Voltage.	10200	12500	volts
DC Grid Voltage: ^e			
From a fixed supply of.	-1500	-1500	volts
From a grid resistor of	2100	1500	ohms
Peak RF Grid Voltage.	2070	2180	volts
DC Plate Current.	3.3	4	amp
DC Grid Current (Approx.)	0.72	1	amp
Driving Power (Approx.) ^f	1350	1960	watts
Power Output (Approx.)	28	40	kw



RF POWER AMPLIFIER and OSCILLATOR — Class C Telegraphy

Key-down conditions per tube without modulation^gMaximum CCS^b Ratings, Absolute-Maximum Values:

DC PLATE VOLTAGE	15000 max.	volts
DC GRID VOLTAGE	-2000 max.	volts
DC PLATE CURRENT	8 max.	amp
DC GRID CURRENT	1 max.	amp
PLATE INPUT	100 max.	kw
PLATE DISSIPATION	25 max.	kw

Typical Operation:

	<i>At 1.6 Mc</i>		
Filament Voltage	10	11	volts
DC Plate Voltage	12500	15000	volts
DC Grid Voltage: ^h			
From a fixed supply of	-1250	-1500	volts
From a cathode resistor of	190	225	ohms
From a grid resistor of	1300	1500	ohms
Peak RF Grid Voltage	1970	2270	volts
DC Plate Current	5.8	6	amp
DC Grid Current (Approx.)	0.95	1	amp
Driving Power (Approx.) ^f	1700	2040	watts
Power Output (Approx.)	55	70	kw

^a When the 5671 is operated at less than maximum ratings, the filament voltage may be reduced to 9.75 volts.

^b CCS Continuous Commercial Service.

^c Averaged over any audio-frequency cycle of sine-wave form.

^d The driving stage should have good regulation and should be capable of supplying considerably more than the required driving power.

^e Obtained from a fixed supply, grid resistor, or a combination of both.

^f Low Frequency driving power is absorbed by the grid and grid resistor and does not include circuit losses. At higher frequencies the power furnished by the driver must be greater because of increased tube and circuit losses.

^g Modulation essentially negative may be used if the positive peak of the audio-frequency envelope does not exceed 115% of the carrier conditions.

^h Obtained from a fixed supply, a cathode resistor, a grid resistor, or from a combination of a fixed supply and self-bias.

CHARACTERISTICS RANGE VALUES FOR EQUIPMENT DESIGN

	Note	Min.	Max.	
Filament Current	1	265	305	amp
Amplification Factor	1,2	35	45	
Direct Interelectrode Capacitances:				
Grid to plate		45	59	μf
Grid to filament		72	104	μf
Plate to filament		1.1	1.9	μf
Plate Voltage	1,3	3200	4200	volts
Plate Voltage	1,4	6700	8700	volts
Grid Voltage	1,5	-310	-490	volts
Grid Voltage	1,6	-	1100	volts

← Indicates a change.



	Note	Min.	Max.	
Peak Cathode Current	7	50	-	amp
Grid Current	1,6	-	9.5	amp
Useful Power Output	1,8	59	-	kw

Note 1: With 11 volts ac on filament.

Note 2: With dc grid voltage of -50 volts and dc plate voltage adjusted to give dc plate current of 2 amperes.

Note 3: With dc grid voltage of 0 volts and dc plate voltage adjusted to give dc plate current of 2 amperes.

Note 4: With dc grid voltage of -100 volts and dc plate voltage adjusted to give dc plate current of 2 amperes.

Note 5: With dc plate voltage of 15000 volts and dc grid voltage adjusted to give dc plate current of 50 ma.

Note 6: With dc plate voltage of 2600 volts and instantaneous grid voltage adjusted to give instantaneous plate current of 35 amperes.

Note 7: Represents the maximum usable cathode current (plate current and grid current) for the tube under any condition of operation.

Note 8: In self-excited oscillator circuit and with dc plate voltage of 15000 volts, dc plate current of 6.6 amperes, dc grid current of 0.8 to 1.0 ampere, grid resistor of $1600 \pm 10\%$ ohms, and frequency of 1.6 Mc.

MAXIMUM RATINGS vs OPERATING FREQUENCY

FREQUENCY	10	18	25	Mc
MAXIMUM PERMISSIBLE PERCENTAGE OF MAXIMUM RATED PLATE VOLTAGE AND INPUT:				
Class C Telephony (Plate-Modulated)	100	88	80	%
Class C Telegraphy	100	88	80	%



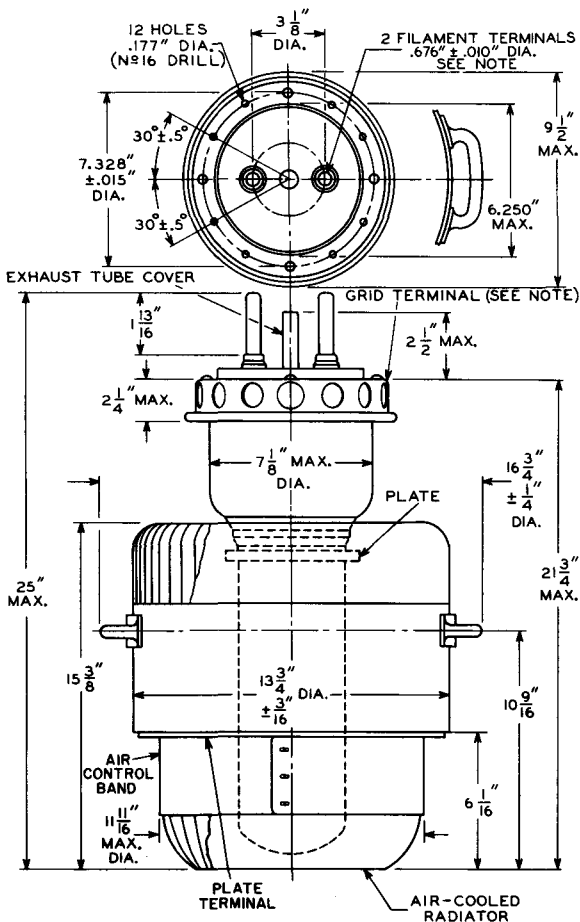

92CM-6897R3

NOTE: FLEXIBLE CONNECTIONS ARE REQUIRED.



TYPICAL PLATE CHARACTERISTICS



92CM-6899RI



TYPICAL CHARACTERISTICS

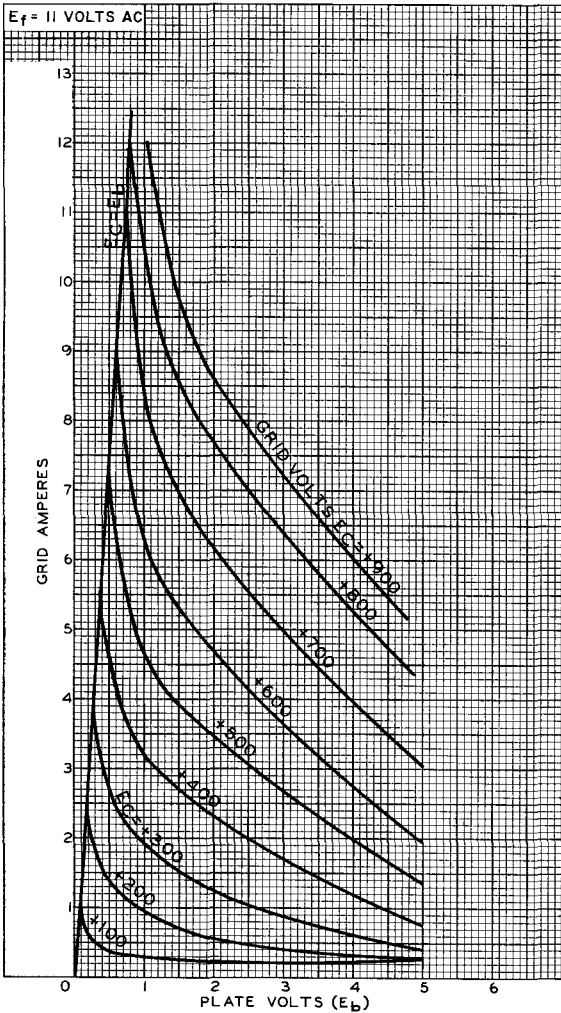

92CM-6900



RADIO CORPORATION OF AMERICA
Electron Tube Division
Harrison, N. J.

DATA 4
9-62

TYPICAL CONSTANT-CURRENT CHARACTERISTICS

